

# PRODUCT INFORMATION PACKET



Model No: A6C34XC21J

Catalog No: 111097.00

3/4HP..3450RPM.56.EPFC./V.1PH.60HZ.CONT.AUTOMATIC.40C.1.0SF.ROUND.EXPLOSION-  
PROOF.A6C34XC21J

Explosion Proof



Regal and Leeson are trademarks of Regal Beloit Corporation or one of its affiliated companies.

©2018 Regal Beloit Corporation, All Rights Reserved. MC017097E





**Nameplate Specifications**

Output HP	<b>0.75 Hp</b>	Output KW	<b>0.56 kW</b>
Frequency	<b>60 Hz</b>	Voltage	<b>115/208-230 V</b>
Current	<b>10.6/5.3-5.3 A</b>	Speed	<b>3450 rpm</b>
Service Factor	<b>1</b>	Phase	<b>1</b>
Efficiency	<b>66 %</b>	Duty	<b>Continuous</b>
Insulation Class	<b>B</b>	Design Code	<b>N</b>
KVA Code	<b>M</b>	Frame	<b>56C</b>
Enclosure	<b>Explosion Proof Fan cooled</b>	Overload Protector	<b>Automatic</b>
Ambient Temperature	<b>40 °C</b>	Drive End Bearing Size	<b>6203</b>
Opp Drive End Bearing Size	<b>6203</b>	UL	<b>Recognized</b>
CSA	<b>N</b>	CE	<b>N</b>
IP Code	<b>54</b>		

**Technical Specifications**

Electrical Type	<b>Capacitor Start Induction Run</b>	Starting Method	<b>Across The Line</b>
Poles	<b>2</b>	Rotation	<b>Selective Counterclockwise</b>
Mounting	<b>Round</b>	Motor Orientation	<b>HORIZONTAL</b>
Drive End Bearing	<b>BALL</b>	Opp Drive End Bearing	<b>BALL</b>
Frame Material	<b>Rolled Steel</b>	Shaft Type	<b>NEMA 56</b>
Overall Length	<b>13.94 in</b>	Frame Length	<b>6.81 in</b>
Shaft Diameter	<b>0.625 in</b>	Shaft Extension	<b>1.88 in</b>
Assembly/Box Mounting	<b>F1 ONLY</b>		
Outline Drawing	<b>B-104188LE-681</b>	Connection Diagram	<b>A-102005-109LE</b>

NAMEPLATES TO BE READ FROM SHAFT EXT. END.

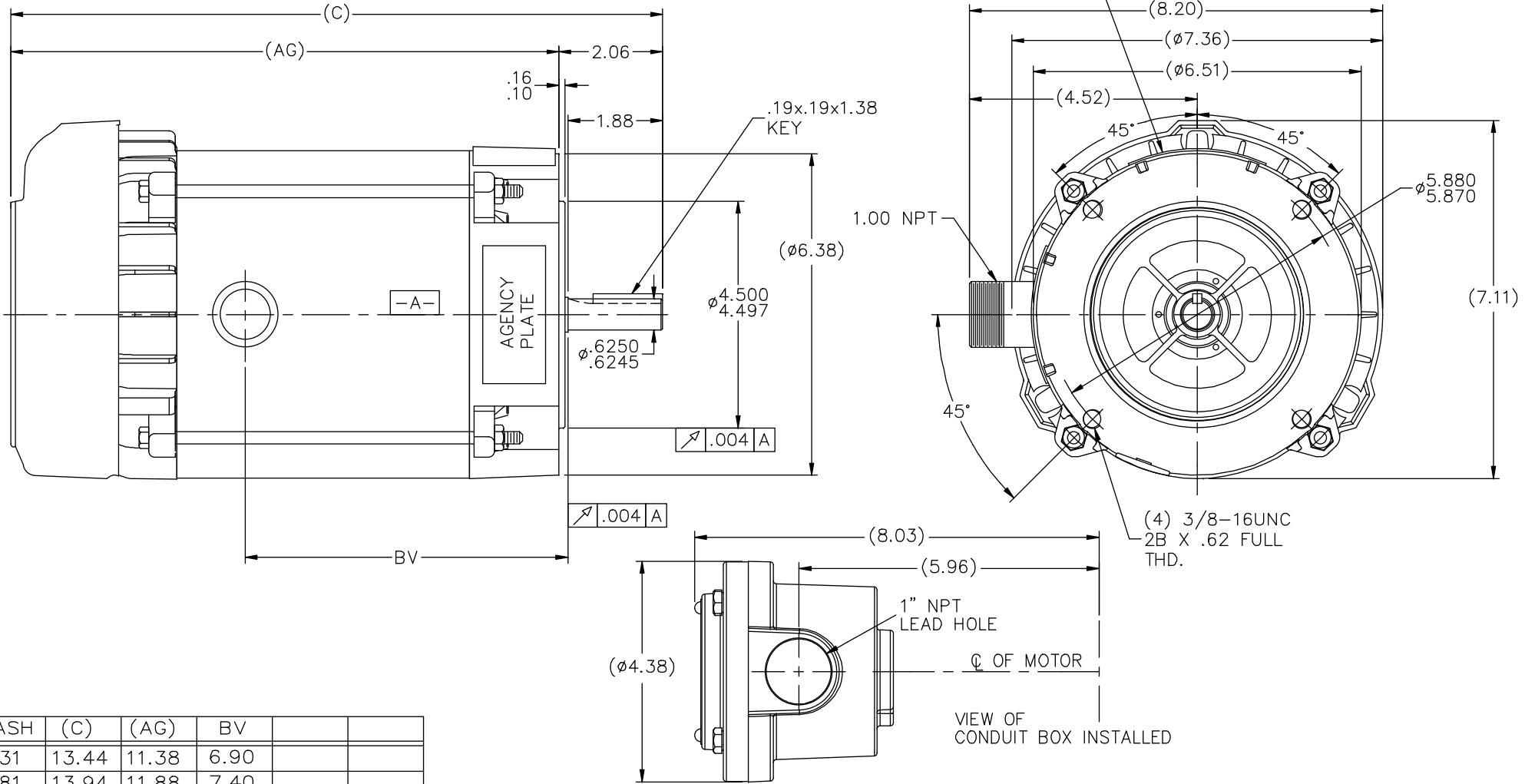

DASH	(C)	(AG)	BV		
631	13.44	11.38	6.90		
681	13.94	11.88	7.40		
731	14.44	12.38	7.90		
781	14.94	12.88	8.40		
831	15.44	13.38	8.90		
881	15.94	13.88	9.40		
931	16.44	14.38	9.90		
981	16.94	14.88	10.40		

		TOLERANCES UNLESS SPECIFIED		 ELECTRIC MOTORS GEARMOTORS AND DRIVES		DRAWN RJW 06-22-2007	
		DEC.	INCHES			CHK	ML 06-22-2007
		.X	±.1			APPD	GK 06-22-2007
		.XX	±.03				SCALE 17=32
		.XXX	±.005			REF	
01	COND. BOX INSTALLED VIEW UPDATED PER ECR-0044571	UD	10/10/13	ST	.XXXX ±.0005	MAT'L	
NO.	REVISION	BY & DATE		CHK	ANG ±7'30"	FINISH	PREV
THIS DRAWING IN DESIGN AND DETAIL IS OUR PROPERTY AND MUST NOT BE USED EXCEPT IN CONNECTION WITH OUR WORK ALL RIGHTS OF DESIGN AND INVENTION ARE RESERVED THIS IS AN ELECTRONICALLY GENERATED DOCUMENT - DO NOT SCALE THIS PRINT				RFP	06-22-2007	CAD FILE	104188LE
				DIST	WP	SIZE	DRAWING NO. PAGE OF REV. B 104188LE 01

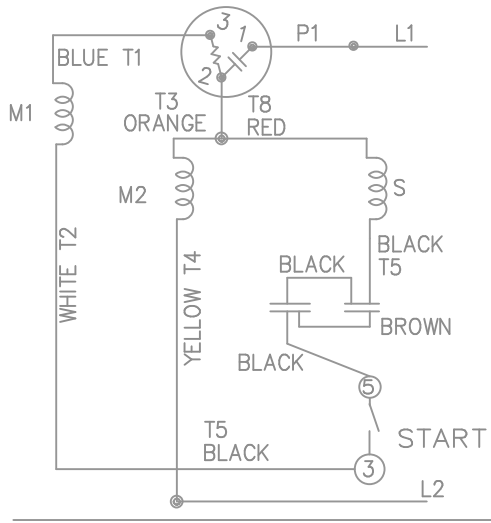

HIGH VOLTAGE - C.C.W.

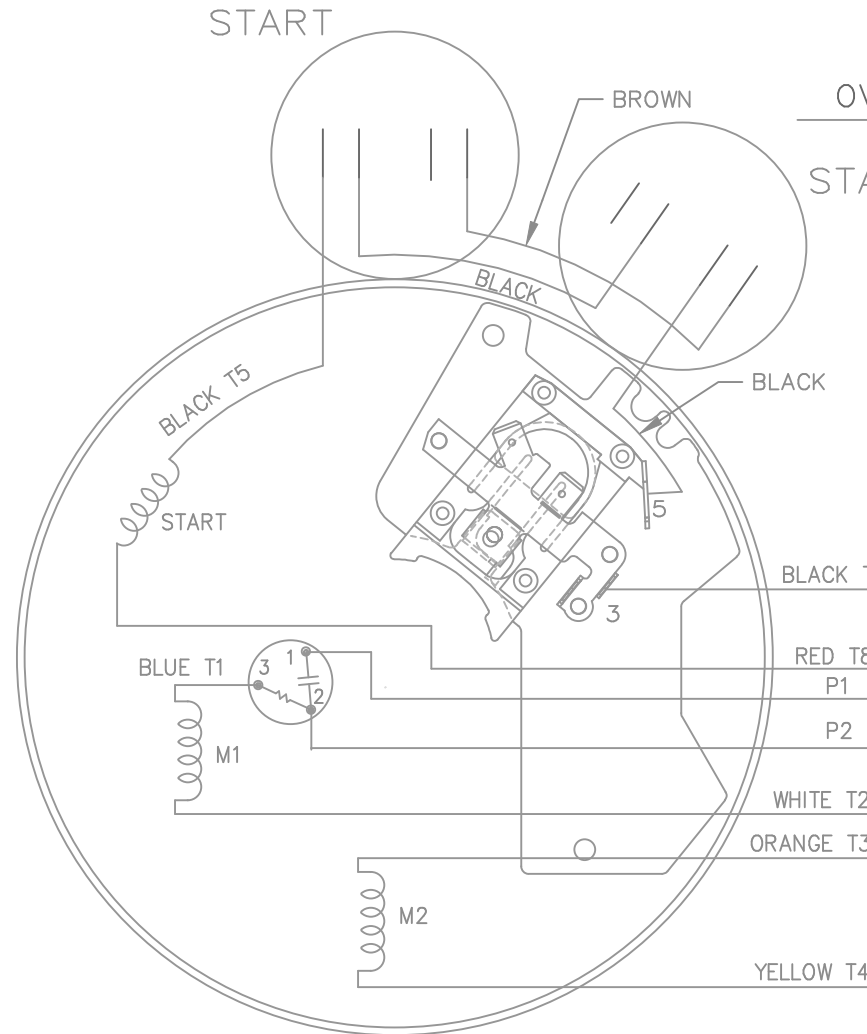
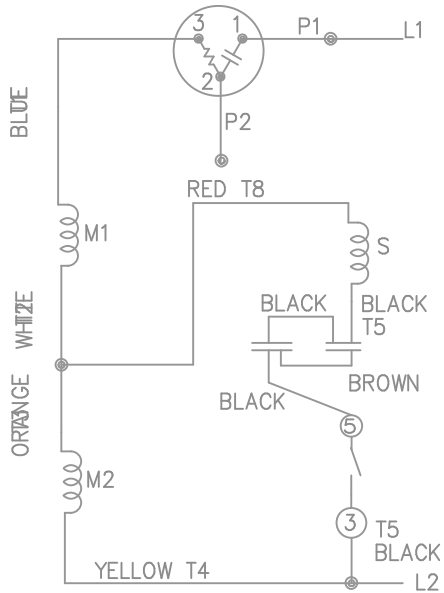

DUAL VOLTAGE CAPACITOR START OVERLOAD SELECT ROT.

LOW VOLT. - C.C.W. ROT.

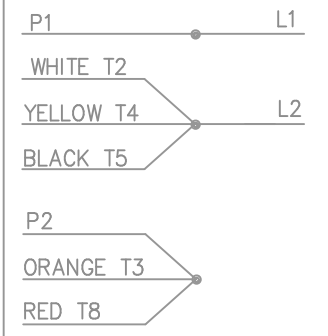

HIGH VOLT. - C.C.W. ROT.

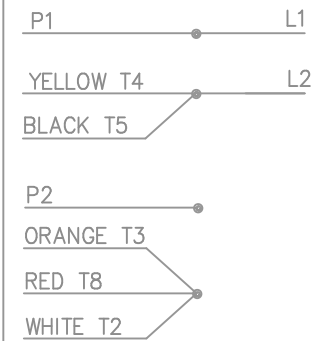

FOR C.W. ROTATION  
EITHER VOLTAGE  
INTERCHANGE RED(T8)  
WITH BLACK(T5) LEAD

				TOLERANCES UNLESS SPECIFIED		ELECTRIC MOTORS GEARMOTORS AND DRIVES  TITLE CONNECTION DIAGRAM  MAT'L.  FINISH	DRAWN MJD 02-11-1998			
				DEC.	INCHES		CHK ML 02-19-1998			
				.X	± -		APPD DAR 02-23-1998			
				.XX	± -		SCALE 5=8			
				.XXX	± -		REF			
				.XXXX	± -	FMF				
NO.	REVISION	BY & DATE	CHK	ANG	± -	PREV				
THIS DRAWING IN DESIGN AND DETAIL IS OUR PROPERTY AND MUST NOT BE USED EXCEPT IN CONNECTION WITH OUR WORK ALL RIGHTS OF DESIGN AND INVENTION ARE RESERVED THIS IS AN ELECTRONICALLY GENERATED DOCUMENT - DO NOT SCALE THIS PRINT				RFP	CAD FILE 102005-109		SIZE A	DRAWING NO. 102005-109LE	PAGE OF	REV. 0
				DIST	WP					



**LEESON ELECTRIC CORPORATION**  
TYPICAL PERFORMANCE CURVE for AC MOTOR

Model No 111097.00

Catalog No 111097.00

Curve at 230 Volts      HP 0.75      PHASE 1  
60 HZ  
0.75 HP      VOLTS 115/208-230

HZ 60      RPM 3450

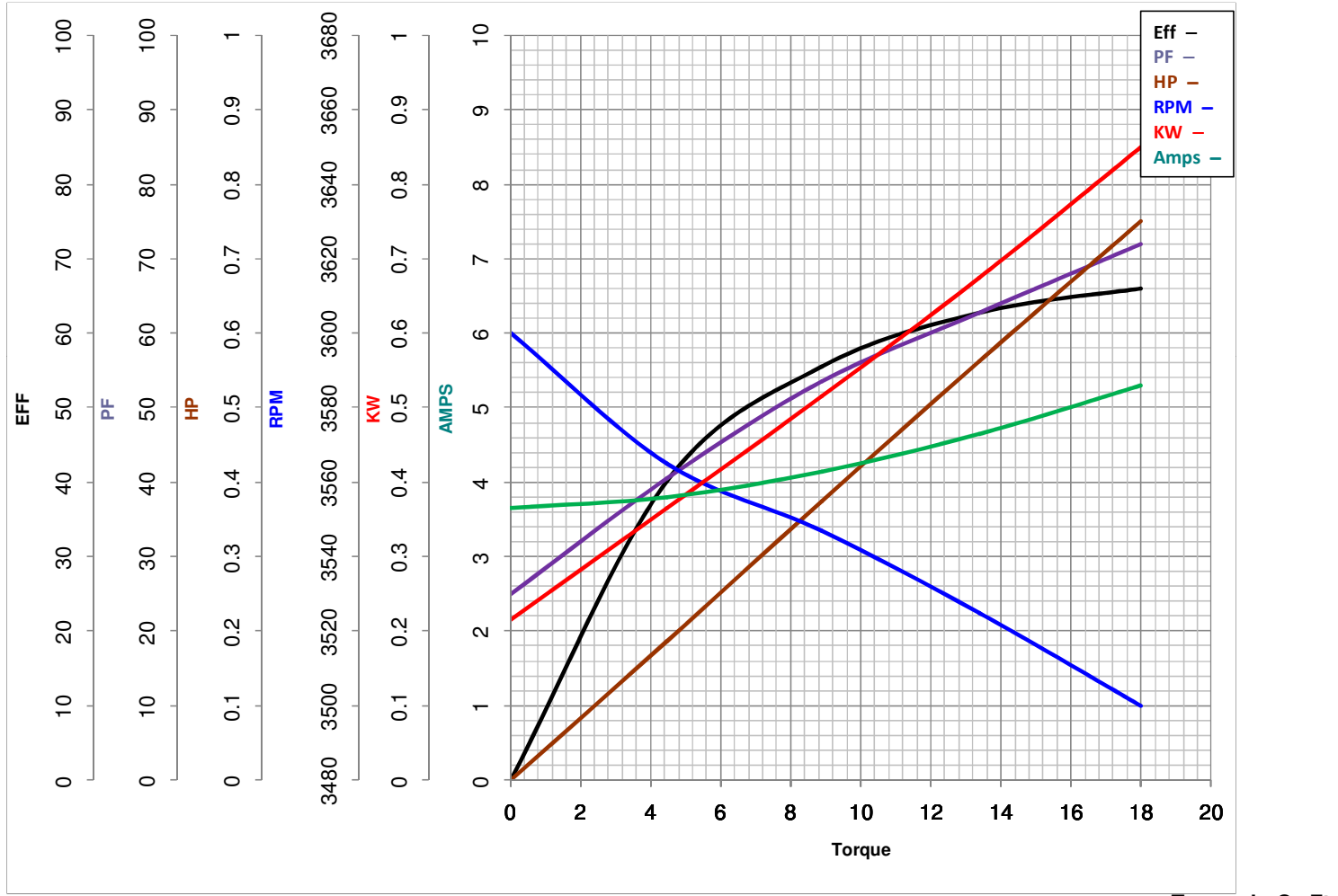

<b>FL TORQUE</b>	<u>18</u>	Oz.Ft	<b>FL AMPS</b>	<u>10.6/5.3-5.3</u>
<b>BD TORQUE</b>	<u>54.1</u>	Oz.Ft	<b>PU TORQUE</b>	<u>48.6</u> Oz.Ft
<b>LR TORQUE</b>	<u>59.6</u>	Oz.Ft	<b>LR AMPS</b>	<u>34.7</u>
<b>WINDING</b>	<u>ZC204-4</u>		<b>Date</b>	<u>5/2/2018</u>